

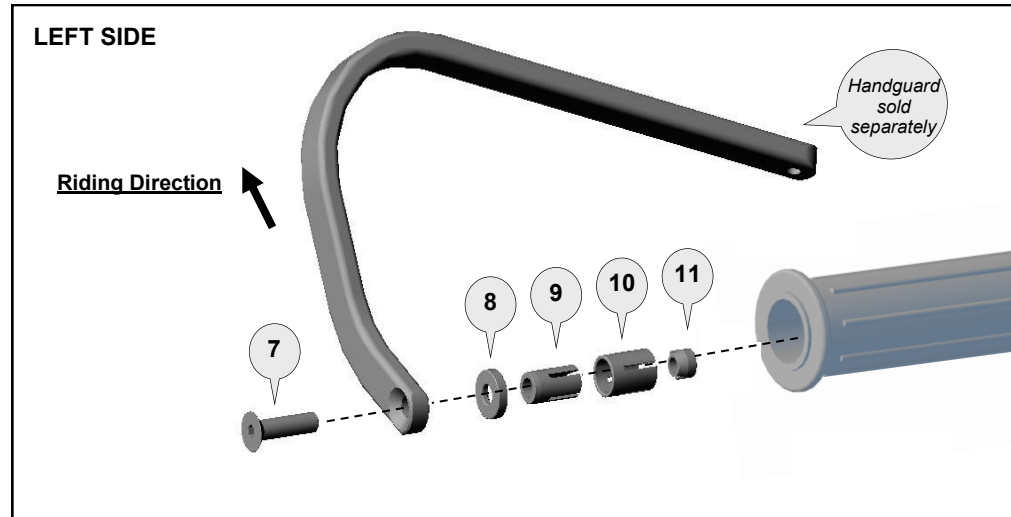

www.barkbusters.net

FITTING INSTRUCTIONS for... Handlebar Clamp Kit (Straight 22mm)

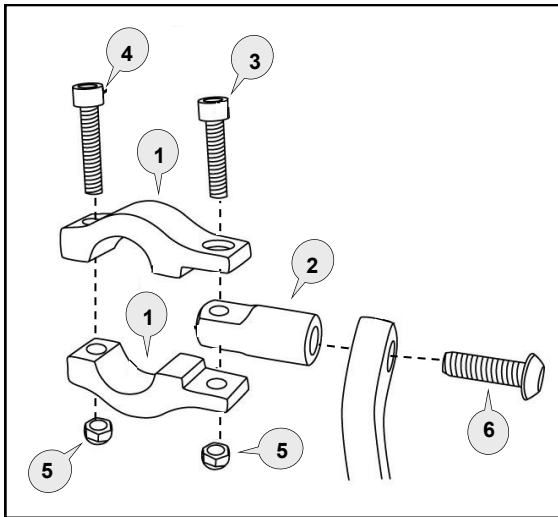

Important Fitting Procedure

Fit Handguard as per handguard fitting instructions.

Loosely assemble the clamp to the handlebar as per diagram. Attach the handguard with applicable parts to the handlebar end and also to the clamp connector (2).

The clamp bolts must be tightened in the following order:

Tighten bolt (6) through the handguard to the clamp connector (2) of the clamp assembly.

Tighten bolt (3) to solidly lock the clamp connector (2) between the clamp saddles (1).

Tighten bolt (4) to secure the clamp assembly firmly to the handlebar.

Note: The clamp is designed to allow the nut on bolt (3) to pull into the recessed hole.
This eliminates the need for a wrench after the bolt starts to tighten.



1 Clamp Saddle



PN: CS-STD
Pcs. 4 pieces

2 Clamp Connector 45mm



PN: CP1
Pcs. 2

3 Socket Head Bolt 25mm



PN: M6x25SHCSZP
Pcs. 2

4 Socket Head Bolt 30mm



PN: M6x30SHCSZP
Pcs. 2

5 Nylock Nut



PN: M6LN
Pcs. 4

6 Button Head Bolt 25mm



PN: M8x25BHCSZP
Pcs. 2

7 Flat Head Bolt 45mm



PN: M8x45FHCSZP
Pcs. 2

8 Collar



PN: BBEC5
Pcs. 2

9 Expander



PN: BBE14A
Pcs. 2

10 Collet



PN: COLLET14-18
Pcs. 2

11 Taper Nut



PN: NUT12
Pcs. 2

Recommended Torque Settings	
M6	10 Nm (7.4 lbf ft)
M8	20 Nm (14.8 lbf ft)

CAUTION:

Installation of a handguard is safety-relevant work and can be complicated. We recommend the installation be performed by a motorcycle service technician. Rideworx accepts no liability for damages caused by improper mounting. All screws, bolts and nuts, including all replacement hardware provided by Rideworx, should be tightened to the torque specified in the below table. After the first 50km of riding check all screws, bolts and nuts are tightened to the correct torque. We recommend a medium strength liquid thread lock product on all fasteners.

WARNING:

Check operation of all handlebar controls, specifically the throttle, front brake, kill switch and clutch to ensure they are operating correctly and are in accordance with the OEM specifications. Do not ride the motorcycle if any controls are not operating correctly. Check periodically that all bolts are tight.



Phone: +61 (0)2 4271 8244
Email: info@barkbusters.net
Web: www.barkbusters.net



Disclaimer:

A failure to follow these fitting instructions could cause serious injury, death or property damage. These handguards are intended solely for use with motorcycles/ATV/snowmobiles/scooters that have not been modified. They are not designed to prevent injury or death while riding or in an accident or crash. The user must ensure that all controls are free of the handguards every time that they ride. By installing and/or using this product you acknowledge that you accept these terms and have followed the fitting instructions.