



FITTING INSTRUCTIONS for...

- KTM 390 Adventure R (2025 - on)
- KTM 390 Adventure X (2025 - on)
- KTM 390 Enduro R (2025 - on)
- KTM 390 SMC R (2025 - on)

www.barkbusters.net

Preparation

Remove original handguard and bar end weight (if applicable). For increased strength we recommend to drill and tap the 6mm handlebar thread to 8mm. Additional bolts & washer can be purchased through your local Barkbusters dealer.

Bar Side View

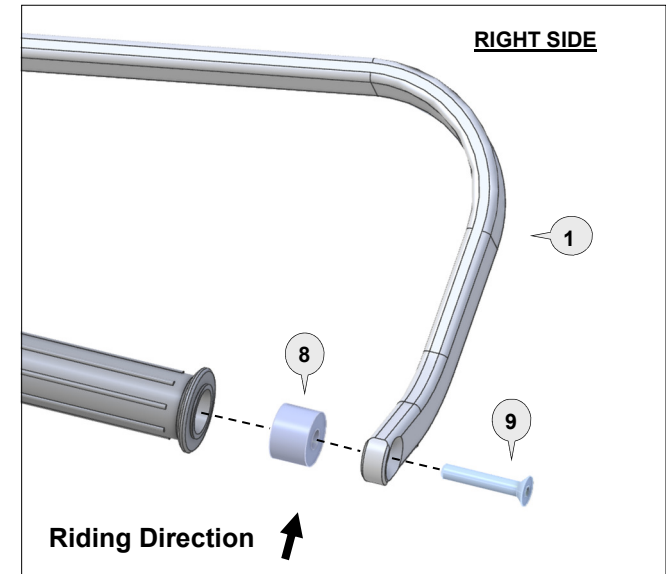
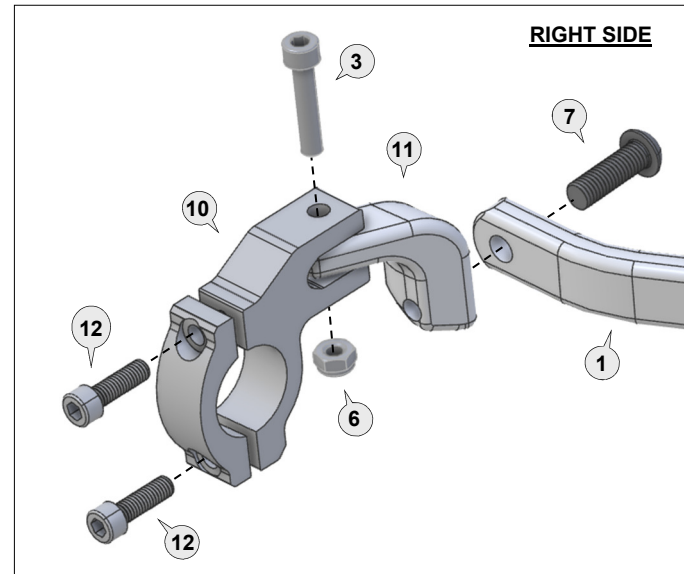
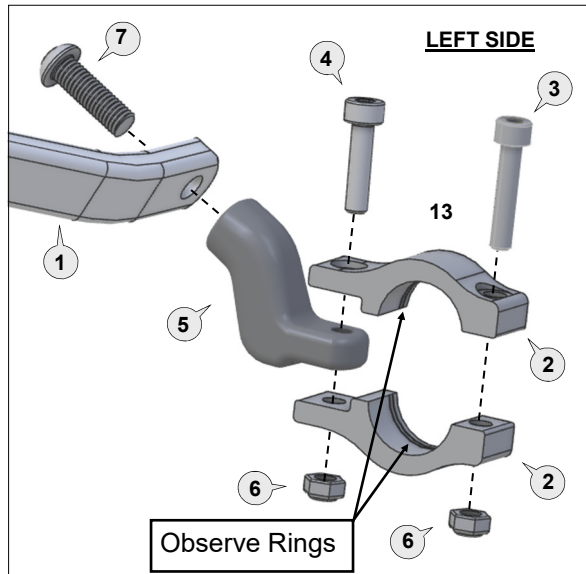
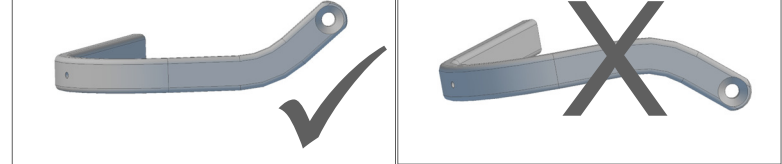







Installation



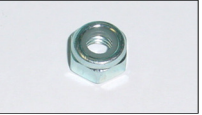

For Left Side:

- Loosely assemble the clamp (2) and clamp connector (5) to the handlebar as per diagram.
- Attach the handguard backbone (1) with applicable parts to the handlebar end using the spacer (8) and also to the clamp connector (5).
- Position backbone so it is horizontal when viewed from the side.
- Tighten all bolts to the specified torque (page 2) in the following order: (9), (7), (4) then (3).

For Right Side:

- Loosely assemble the clamp (10) and clamp connector (11) to the handlebar as per diagram.
- Attach the handguard backbone (1) with applicable parts to the handlebar end using the spacer (8) and also to the clamp connector (11).
- Position backbone so it is horizontal when viewed from the side.
- Tighten all bolts to the specified torque (over page) in the following order: (9), (7), (12, evenly) then (3).
- If additional grip clearance is required, washer (13) can be used between the handlebar end and spacer (8)

<p>1 Aluminium Bar</p>  <p>PN: BAR-V070 Pcs. Left/Right Pair</p>	<p>2 Clamp Saddles</p>  <p>PN: CS-02 Pcs. 1 pairs</p>	<p>3 Socket Head Bolt 30mm</p>  <p>PN: M6X30SHCSZP Pcs. 2</p>	<p>4 Socket Head Bolt 25mm</p>  <p>PN: M6X25SHCSZP Pcs. 1</p>	<p>5 Clamp Connector</p>  <p>PN: CP5 Pcs. 1</p>	<p>6 Nylock Nut 6mm</p>  <p>PN: M6LN Pcs. 3</p>	<p>7 Button Head Bolt 25mm</p>  <p>PN: M8X25BHCSZP Pcs. 2</p>	<p>8 Spacer (15mm)</p>  <p>PN: SP22 Pcs. 2</p>
--	---	---	--	---	---	---	--

<p>9 Flat Head Bolt 35mm</p>  <p>PN: M6X35FHCSZP Pcs. 2</p>	<p>10 Multi Fit Clamp LEFT</p>  <p>PN: MFC-L Pcs. 1 set</p>	<p>11 Connector LEFT</p>  <p>PN: CP8-L Pcs. 1</p>	<p>12 Socket Head Bolt 20mm</p>  <p>PN: M6X20SHCSZP Pcs. 2</p>	<p>13 M8 Flat Washer</p>  <p>PN: M8FW-SS Pcs. 2</p>
---	---	---	---	---

Recommended Torque Settings	
M6	10 Nm (7.4 lbf ft)
M8	28 Nm (20.7 lbf ft)

CAUTION:

Installation of the handguard is safety-relevant work and can be complicated. We recommend the installation be performed by a motorcycle service technician. Rideworx accepts no liability for damages caused by improper mounting. All screws, bolts and nuts, including all replacement hardware provided by Rideworx, should be tightened to the torque specified in the table. After the first 50km of riding check all screws, bolts and nuts are tightened to the correct torque. We recommend a medium strength liquid thread lock product on all fasteners.

WARNING:

It is important there is a working clearance (approx 3mm) between the throttle grip end and the handguard to ensure a free closing throttle. Check operation of all handlebar controls, specifically the throttle, front brake, kill switch and clutch to ensure they are operating correctly and are in accordance with the OEM specifications. Do not ride the motorcycle if any controls are not operating correctly. Check periodically that all bolts are tight. Please note that all Rideworx test fitment are done on stock motorcycles with factory standard handle bar, windscreen, etc. in there original positions.

Disclaimer:

A failure to follow these fitting instructions could cause serious injury, death or property damage. These handguards are intended solely for use with motorcycles/ATV/snowmobiles/scooters that have not been modified. They are not designed to prevent injury or death while riding or in an accident or crash. The user must ensure that all controls are free of the handguards every time that they ride. By installing and/or using this product you acknowledge that you accept these terms and have followed the fitting instructions.

Personalise Your Protection
Guard options sold separately

JET JET-003
VPS VPS-003
Storm STM-003
CARBON BCF-003



Email: info@barkbusters.net

@BARKBUSTERSHANDGUARDS

