



www.barkbusters.net

FITTING INSTRUCTIONS for...

- KLR650 ('22 on)

IMPORTANT FITTING TIP:

OEM bar end weight are Loctited in, high torque may be required to remove the bolt. We advise running a tap through to clean thread before fitting 8mm screw provided in the kit. The wiring loom attached to the bar will need to be moved to fit the clamp.

Preparation

Remove original bar end weight and handguards if fitted.

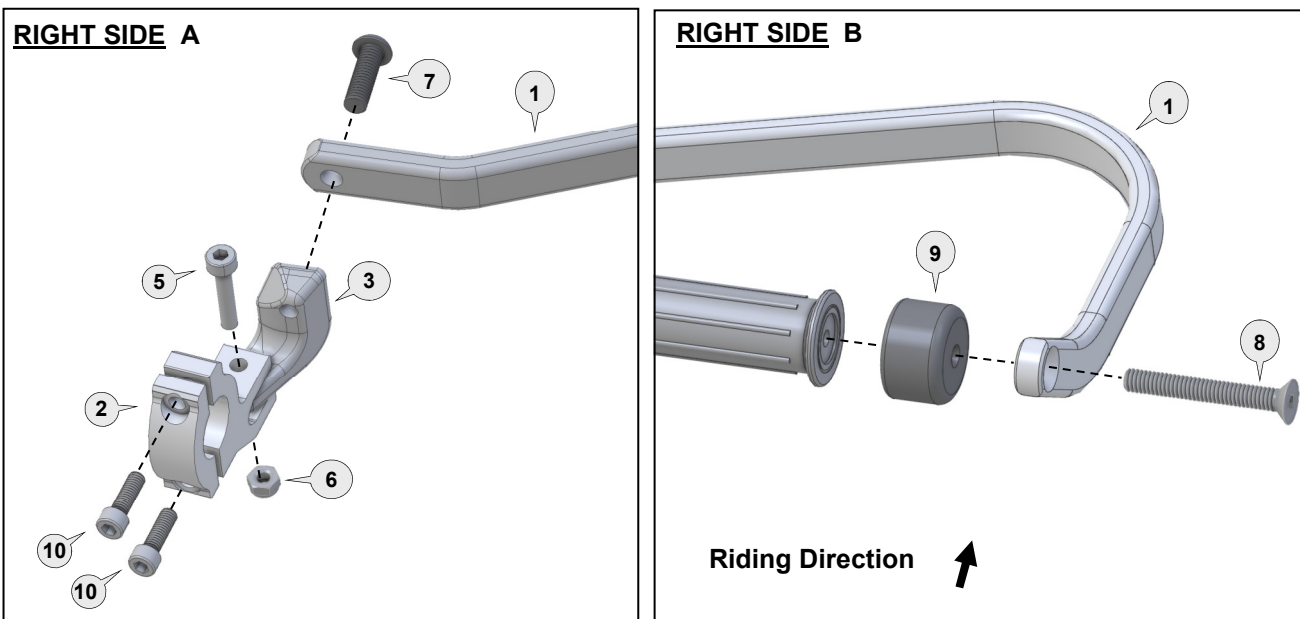

Installation for Right Side.

Repeat for Left side with applicable parts.









- Loosely assemble the clamp to the handlebar as per diagram (A).
- Attach the handguard backbone (1) with applicable parts to the handlebar end and also to the clamp connector (3).
- Position backbone so it is horizontal when viewed from the side.
- Tighten all bolts in the following order: (8), (7), (10) then (5).



Important: Use the specified torque setting over page.

For Maximum Clearance



The handlebar is best in the neutral position. If rolled forward, the hand guard can contact fairing. Depending on your personal riding position, handlebar (10mm riser) and lever adjustment may be required.

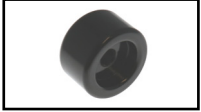

<p>1 Aluminium Bar</p>  <p>PN: BAR-V-043 Pcs. Left/Right Pair</p>	<p>2 Multi Fit Clamp 22mm</p>  <p>PN: MFC-22 Pcs. 2</p>	<p>3 Connector RIGHT</p>  <p>PN: CP8-R Pcs. 1</p>	<p>4 Connector LEFT</p>  <p>PN: CP8-L Pcs. 1</p>	<p>5 Socket Head Bolt 30mm</p>  <p>PN: M6X30SHCSZP Pcs. 2</p>	<p>6 Nylock Nut 6mm</p>  <p>PN: M6LN Pcs. 2</p>	<p>7 Button Head Bolt 25mm</p>  <p>PN: M8X25BHCSZP Pcs. 2</p>	<p>8 Counter Sunk Bolt 35mm</p>  <p>PN: M8X45FHCSZP Pcs. 2</p>
---	---	---	---	---	---	---	--

<p>9 Bar End Weight</p>  <p>PN: BEW35 Pcs. 2</p>	<p>10 Socket Head Bolt 20mm</p>  <p>PN: M6X20SHCSZP Pcs. 4</p>
--	--

Personalise Your Protection
Guard options sold separately

	JET-003
	VPS-003
	STM-003
CARBON	BCF-003

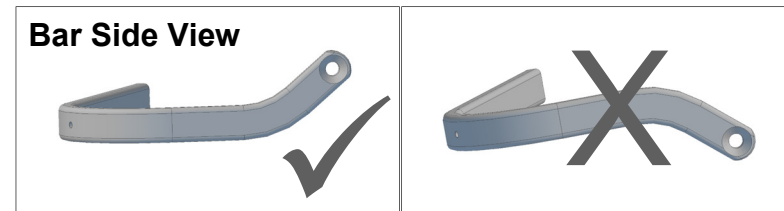

Recommended Torque Settings	
M6	10 Nm (7.4 lbf ft)
M8	20 Nm (14.8 lbf ft)

CAUTION:

Installation of the handguard is safety-relevant work and can be complicated. We recommend the installation be performed by a motorcycle service technician. Rideworx accepts no liability for damages caused by improper mounting. All screws, bolts and nuts, including all replacement hardware provided by Rideworx, should be tightened to the torque specified in the table. After the first 50km of riding check all screws, bolts and nuts are tightened to the correct torque. We recommend a medium strength liquid thread lock product on all fasteners.

WARNING:

It is important there is a working clearance (approx 3mm) between the throttle grip end and the handguard to ensure a free closing throttle. Check operation of all handlebar controls, specifically the throttle, front brake, kill switch and clutch to ensure they are operating correctly and are in accordance with the OEM specifications. Do not ride the motorcycle if any controls are not operating correctly. Check periodically that all bolts are tight.

Disclaimer:

A failure to follow these fitting instructions could cause serious injury, death or property damage. These handguards are intended solely for use with motorcycles/ATV/snowmobiles/scooters that have not been modified. They are not designed to prevent injury or death while riding or in an accident or crash. The user must ensure that all controls are free of the handguards every time that they ride. By installing and/or using this product you acknowledge that you accept these terms and have followed the fitting instructions.



Phone: +61 (0)2 4271 8244
Email: info@barkbusters.net
Web: www.barkbusters.net

